

IB899

Intel® Braswell

USER'S MANUAL

Version 1.1

Acknowledgments

AMI BIOS is a trademark of American Megatrends Inc. PS/2 is a trademark of International Business Machines Corporation. Intel and Luna-Pier are registered trademarks of Intel Corporation. Microsoft Windows is a registered trademark of Microsoft Corporation. Winbond is a registered trademark of Winbond Electronics Corporation. All other product names or trademarks are properties of their respective owners.

Table of Contents

Introduction	1
Checklist.....	2
IB899 Specifications	3
Board Dimensions	5
Installations	6
Installing the Memory	7
Setting the Jumpers	8
Connectors on IB899.....	15
BIOS Setup.....	33
BIOS Introduction	34
BIOS Setup.....	34
Advanced Settings	35
CSM Configuration.....	43
Chipset Settings	45
Security Settings	46
Boot Settings	47
Save & Exit Settings	48
Drivers Installation	49
Intel Chipset Software Installation Utility.....	50
VGA Drivers Installation	53
Realtek HD Audio Driver Installation.....	55
LAN Drivers Installation.....	56
TXE Drivers Installation	59
Appendix	61
A. I/O Port Address Map.....	61
B. Interrupt Request Lines (IRQ)	62
C. Watchdog Timer Configuration.....	63

This page is intentionally left blank.

Introduction

IB899 is a 3.5-inch Disk Size SBC (102mm x 147mm) that comes with the Intel® Pentium® N3700 \ N3710 and Celeron® N3000 \ N3010 series processor. It has two DDR3L SO-DIMM sockets supporting up to 8GBs of system memory. It also features the Intel® Gen8-LP graphics engine with interface for CRT, DVI-D and 24-bit dual channel LVDS displays. The platform provides four connectors of USB 3.0 at the board edge and USB 2.0 two ports with pin header. Two SATA III ports are included.

IB899 Features

- 3.5-inch Disk Size SBC, 142mm x 102mm
- Onboard Intel® Pentium® N3700 \ N3710 series
Celeron® N3000 \ N3010 series
- Two DDR3L SO-DIMM sockets, DDR3L-1600, Max. 8GB
- Intel® Gen8-LP graphics for CRT, DVI-D interface
- 24-bit dual channel LVDS interface
- Dual Intel I211-AT PCIe Gigabit LAN
- 4 x USB 3.0 on edge, 2 x USB 2.0 on board support
- Two SATA III, 2 x COM ports
- Digital I/O 4-in / 4-out, 1 x Full-size Mini-PCIe, 1 x Half-size Mini-PCIe
- Watchdog Timer, iSMART, RoHS compliance

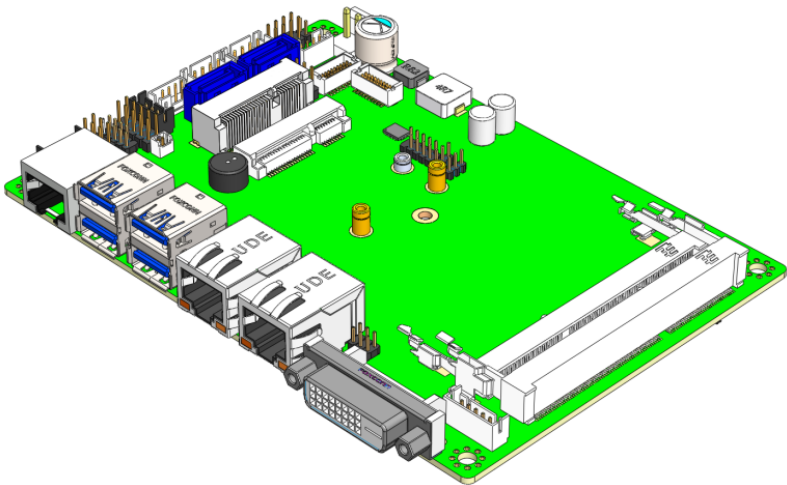

Checklist

Your IB899 package should include the items listed below.

- 3.5-inch Disk Size SBC
- This User's Manual
- 1 CD containing chipset drivers and flash memory utility
- Serial ATA cable
- I/O shield

IB899 Specifications

Product Name	<p>IB899F-370(N3700 onboard) IB899F-371(N3710 onboard) IB899F-300(N3000 onboard) IB899F-301(N3010 onboard) IB899A-370 (N3700 onboard, w/MicroSD & TPM 2.0) IB899A-371 (N3710 onboard, w/MicroSD & TPM 2.0) **Default silk screen model # on PCB is IB899F**</p>
Form Factor	3.5"
SoC Type/Speed	<p>14nm Technology Process, FCBGA1170, Package= 25mm x 27mm</p> <ul style="list-style-type: none"> - Pentium® N3700 QC, up to 2.4Ghz , TDP=6W (CO-stepping, SR2A7) - Pentium® N3710 QC, up to 2.56Ghz , TDP=6W (D1-stepping, SR2KL) - Celeron® N3000 DC, up to 2.08GHz, TDP=4W (CO-stepping, SR29J) - Celeron® N3010 DC, up to 2.24GHz, TDP=4W (D1-stepping, SR2KM)
Cache	2MB
BIOS	AMI BIOS
Memory	<p>Intel® Pentium®/Celeron® SoC integrated memory controller 2 x DDR3 SO-DIMM socket, Support DDR3L (1.35V) only Max. memory to 8GB (Non-ECC, Un-buffered)</p>
VGA	<p>Intel® Pentium®/Celeron® SoC integrated Gen 8 graphics Support 3 x independent displays, DX11.1 (DX12 for Win 10) & OpenGL 4.2</p> <ul style="list-style-type: none"> - VGA x 1: Thru NXP PTN3392 DP to VGA **1920x1200 @ 60 Hz** (C0133392BSF415000P) - DVI-D x 1 ** 2560x1600@ 60 Hz** - LVDS: 24-bit dual channel via NXP PTN3460 thru eDP **1920x1200 @ 60 Hz** (C01Z3460BSF612000P)
LAN	Intel® I211-AT PCIe Gigabit LAN x 2
USB (Universal Serial Bus)	<p>Intel® Pentium®/Celeron® SoC built-in USB 3.0 host controller, support 4 ports</p> <ul style="list-style-type: none"> - Edge I/O x 4 <p>Intel® Pentium®/Celeron® SoC built-in USB 2.0 host controller with USB hub Renesas uPD720115K8-611-BAK-A(C013720115K861000P) For total 4 ports x USB 2.0</p> <ul style="list-style-type: none"> - 2 Ports thru pin header - 2 Ports thru Mini PCIe slot
Serial ATA Ports	Intel® Pentium®/Celeron® SoC built-in SATA III controller, supports 2 ports
Audio	Intel® Pentium®/Celeron® SoC built-in HD Audio controller + Realtek ALC662 Codec
LPC I/O	<p>Nuvoton NCT5523D, Ver. C [64-pin LQFP, 7x7x1.4mm] COM #1 (RS232/422/485)</p> <ul style="list-style-type: none"> - With EXAR SP339 (C014339EER1L29000P) x 1 for jumper-less - Support ring-in with power @500 mA (selectable for 5V or 12V) <p>COM #2 (RS-232 only) [Hardware Monitor] 2 x Thermal inputs; 2 x Voltage monitoring</p>
Digital IO	4 in & 4 out
Expansion Slots	<p>Mini PCIe socket x 2 Full-sized x1 : with USB 2.0 signal + support mSATA(via NXP switch) Half-sized x1: with USB 2.0 signal</p>
Edge Connectors	<p>DVI-D x 1 for DVI COM x 1 (RJ45 connector type) RJ45 x 2 for LAN 1 & 2 USB 3.0 stack connector x 1 for 2 ports (from SoC) USB 3.0 stack connector x 1 for 2 ports (from SoC)</p>

INTRODUCTION

Onboard Header/ Connector	<p>DF11 2 x 4 pins header x 1 for 2 x USB 2.0 DF20 socket connector x 2 for 24-bit dual channel LVDS (C1220220020220300P) 4 pins box header x 1 for backlight/brightness control (PWM mode) DF11 2 x 6 pins box header x1 for Audio DF11 2 x 8 pins box header x 1 for VGA DF11 2 x 5 pins box header x 1 for COM2 2 x 5 pins header x 1 for LPC(80-port card debugging purpose) Mini PCI-e(1x) connector x 2 SATA III connector x 2 for SATA device(BLUE color) 4-pins power connector x 2 (JST type, For SATA III device) 2 x 4 pins pin-header x 1 for front I/O (RST, PWR, LEDs) 2-pins connector x 1 for power input (C12101112202101HAP) Micro SD slot x 1 @ solder side (IB899A only) BR2032 w/ adhesive tape = C272113012032B100P+ M1401020010010100</p>
Watchdog Timer	Yes (256 segments, 0, 1, 2...255 sec/min)
DC Input	9V~+24V ($\pm 5\%$ tolerance)
TPM 2.0	Infineon SL9665 (IB899A-370 only) [C01Z9665TT2007000P] Infineon SL9665 (IB899A-371 only) [C01Z9665TT2007000P]
Others	iSMART 3.2
OS support	<p>** Please note the priority**</p> <ul style="list-style-type: none"> - Windows 8.1(64-bit) - Windows 7(64-bit, refer to Intel #558302 EHCI OS USB installation guide) - Fedora (Installation) - Ubuntu (Installation) - Windows 10 (32-bit / 64-bit) - Embedded OS will be test by request
RoHS / REACH/ LVD /CE	Yes / Yes / Yes / Class B
Operating system	0° C to +60° C
Board Size	102mm x 147mm

Board Dimensions

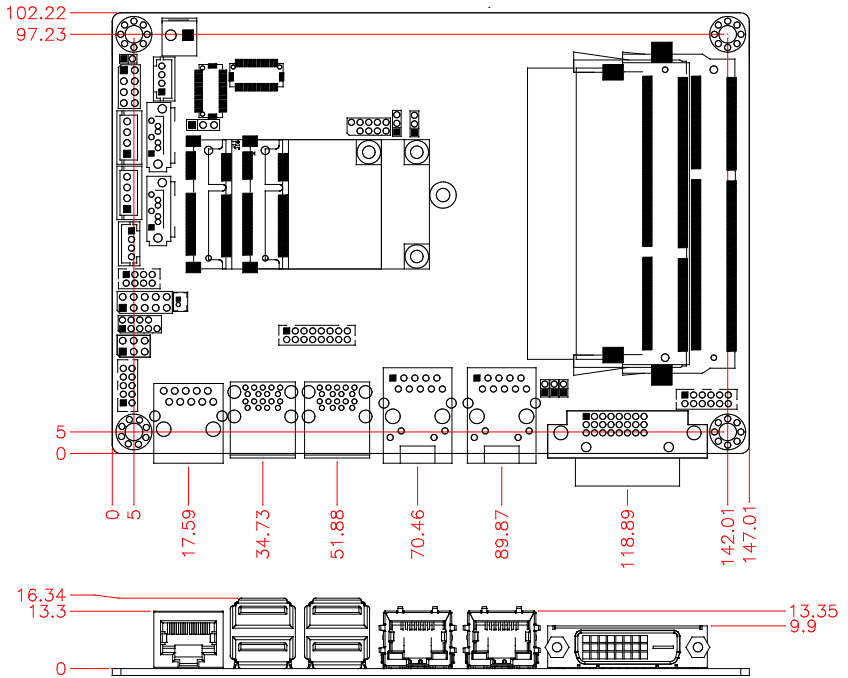

Installations

This section provides information on how to use the jumpers and connectors on the IB899 in order to set up a workable system. The topics covered are:

Installing the Memory	7
Setting the Jumpers	8
Connectors on IB899	15

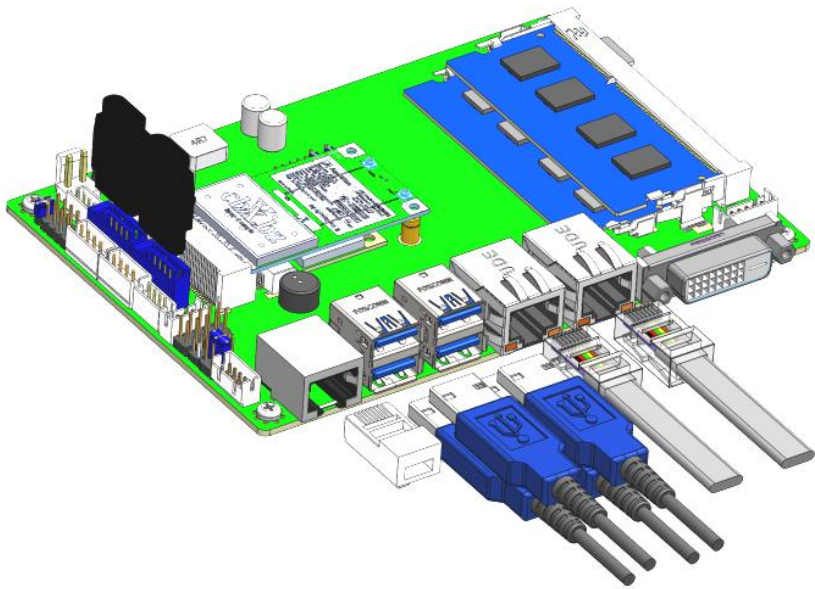

Installing the Memory

The IB899 board supports two DDR3L-1600 memories.

Installing and Removing Memory Modules

To install the DDR3 modules, locate the memory slot on the board and perform the following steps:

1. Hold the DDR3 module so that the key of the DDR3 module aligned with that on the memory slot.
2. Gently push the DDR3 module in an upright position until the clips of the slot close to hold the DDR3 module in place when the DDR3 module touches the bottom of the slot.
3. To remove the DDR3 module, press the clips with both hands.

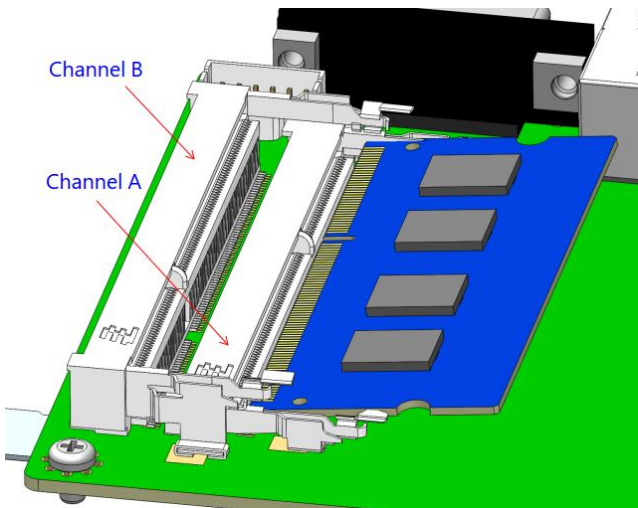

Setting the Jumpers

Jumpers are used on IB899 to select various settings and features according to your needs and applications. Contact your supplier if you have doubts about the best configuration for your needs. The following lists the connectors on IB899 and their respective functions.

Jumper Locations on IB899	9
JP1: LCD Backlight Voltage Selection.....	10
JP2: Clear RTC	10
JP3: Clear CMOS Setting	11
JP4: LCD Panel Voltage Selection	11
JP5: COM1 Ring Pin Function Selection.....	12
JP6: Security Flash Descriptors (For Factory Use Only)	13
JP7/JP8: OS Type Selection.....	13

Jumper Locations on IB899

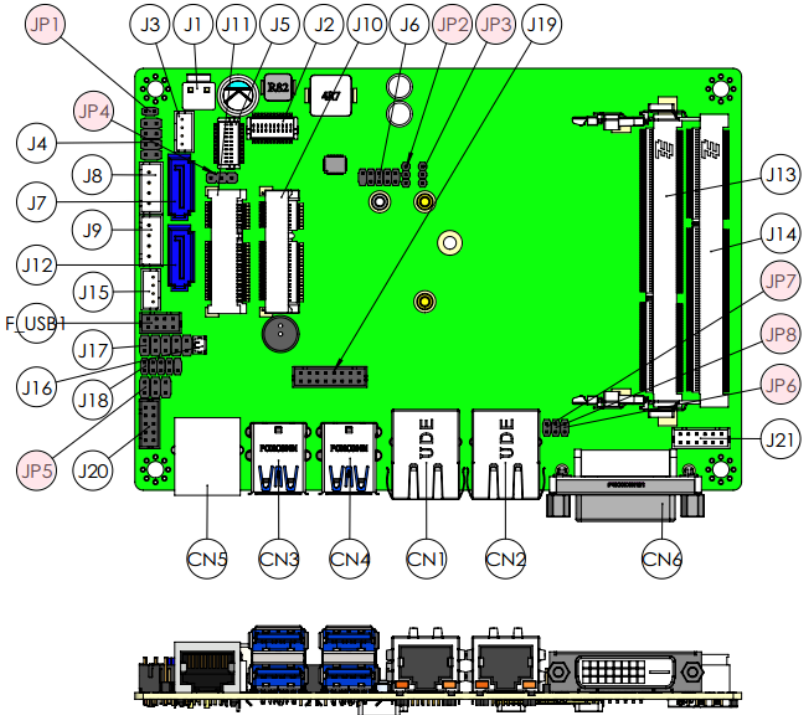

JP1: LCD Backlight Voltage Selection

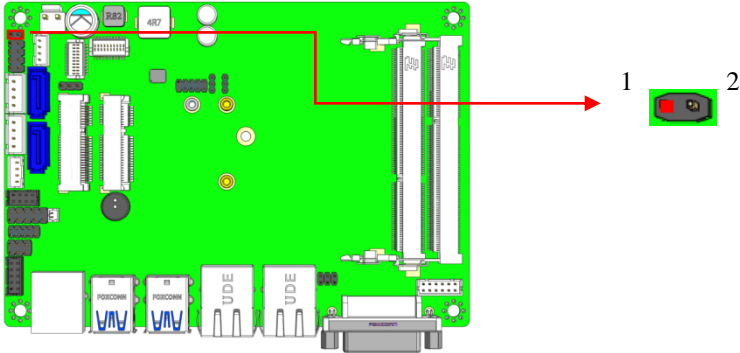

JP1	Setting
	+3.3V
	+5V

JP2: Clear RTC

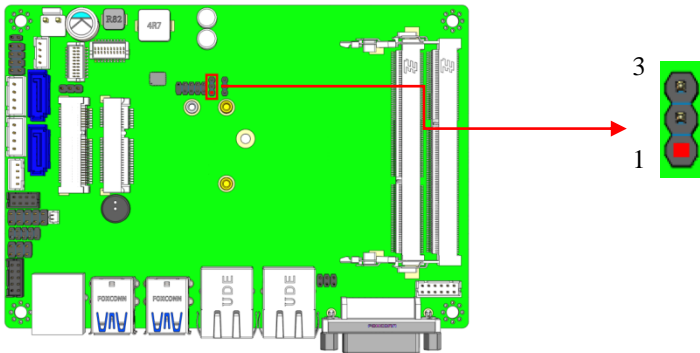



JP2	Setting
	Save RTC*
	Clear RTC

*: Default Setting

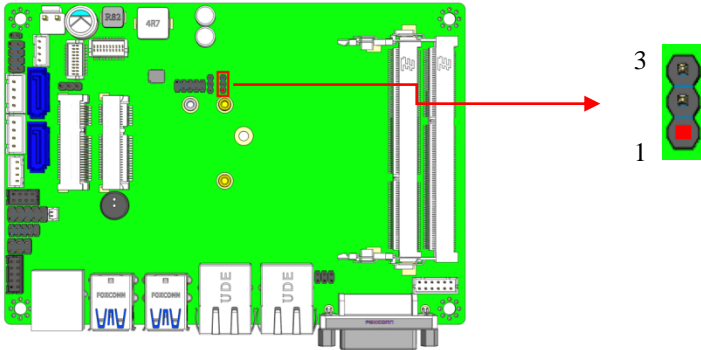
JP3: Clear CMOS Setting





JP3	Setting
	Save CMOS*
	Clear CMOS

*: Default Setting

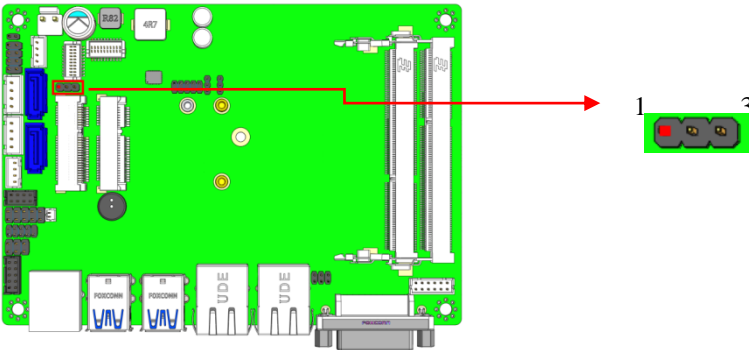
JP4: LCD Panel Voltage Selection



JP4	LCD Panel Power
	+3.3V*
	+5V

*: Default Setting

JP5: COM1 Ring Pin Function Selection

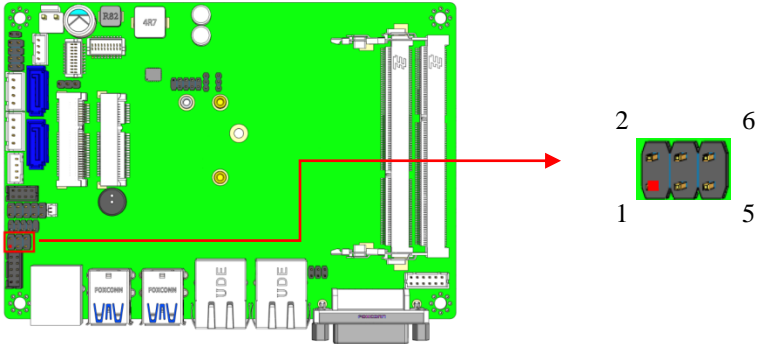

JP5	Setting
	+12V
	Ring*
	+5V

*: Default Setting

JP6: Security Flash Descriptors (For Factory Use Only)

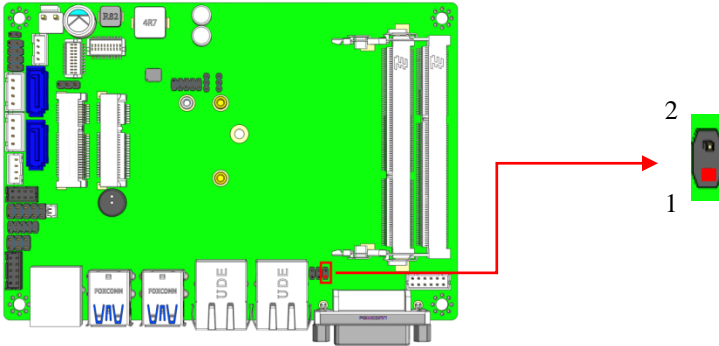

JP6	Setting
	Open*
	Close

*: Default Setting

JP7/JP8: OS Type Selection

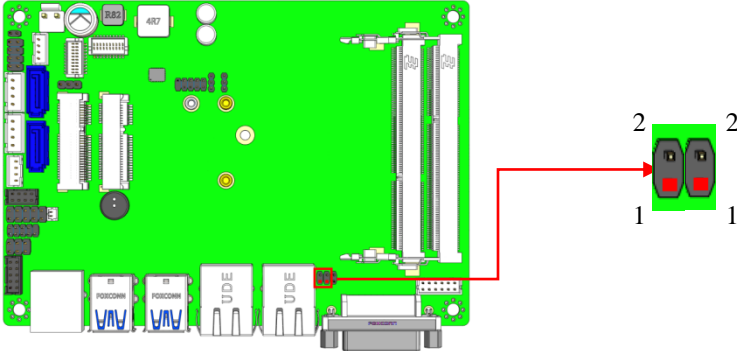

JP7/JP8	Setting
	Win8/Android
	Linux
	DOS, Win 7 Legacy
	N/A

INSTALLATIONS

*: Default Setting

Connectors on IB899

The connector on IB899 allows you to connect external devices such as keyboard, floppy disk drives, hard disk drives etc. The following table lists the connectors on IB899 and their respective functions.

Connector Locations on IB899	16
CN1/CN2: Gigabit LAN Port #2 / #1 Connectors	17
CN1: Port #2 CN2: Port #1	17
CN3/CN4: USB 3.0 Connectors	17
CN5: COM1 in RJ45 10P10C Type Connector	18
CN6: DVI-D Connector	19
CN7: Micro SD Connector (On Bottom Side)	20
J1: Power Input Connector	20
J2/J5: Dual Channel LVDS Connector	21
J2 (Channel A) Pin Assignment	21
J5 (Channel B) Pin Assignment	21
J3: Backlight LCD Panel Power Connector	22
J4: Front Panel Pin Header	22
J6: SPI Flash Burn-in Pin Header	23
J7/J12: Serial ATA III Connectors	24
J8/J9: SATA HDD Power Connectors	24
J10: Half-sized Mini PCIe Sockets	25
J11: Full-sized Mini PCIe Socket	25
J13/J14: DDRIII SO-DIMM Sockets	27
J15: MCU Burn-in Connector	28
J16: Battery Connector	28
J17: Digital I/O Connector	29
J18: LPC Debug Connector	29
J19: VGA Connector	30
J20: COM2 Connector	31
J21: Audio Connector	31
F_USB1: USB2.0 Connector	31

Connector Locations on IB899

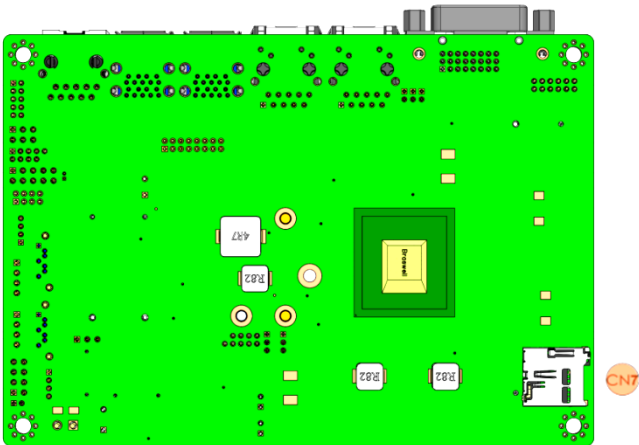
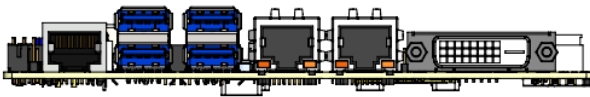
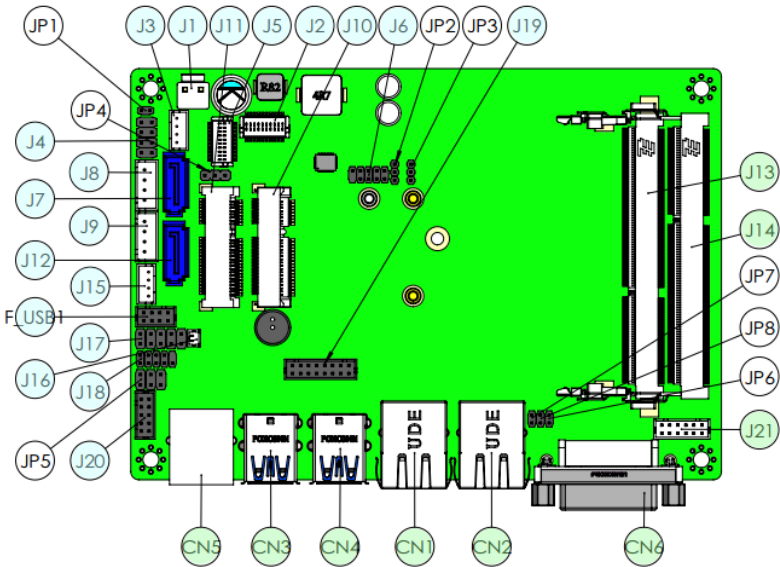

CN1/CN2: Gigabit LAN Port #2 / #1 Connectors

CN1: Port #2

CN2: Port #1

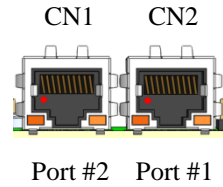
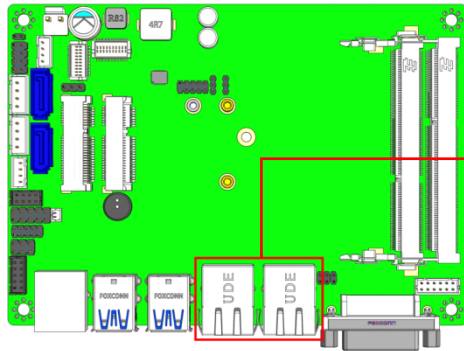

Signal Name	Pin #	Pin #	Signal Name
TX+	1	2	TX-
RX+	3	4	RX-
TCT	5	6	RCT
MDI2+	7	8	MDI2-
MDI3+	9	10	MDI3-

CN3/CN4: USB 3.0 Connectors

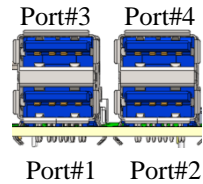
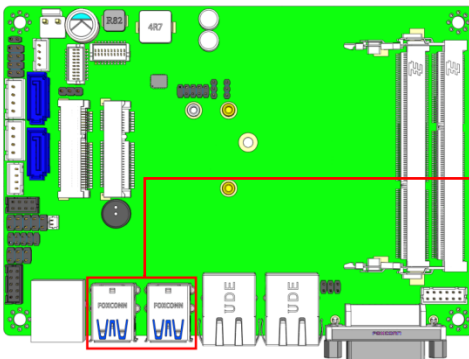

CN3 CN4



Signal Name	Pin #	Pin #	Signal Name
VBUS	1	2	DATA-
DATA+	3	4	GND
SSRX-	5	6	SSRX+
GND	7	8	SSTX-
SSTX+	9		

INSTALLATIONS

CN5: COM1 in RJ45 10P10C Type Connector

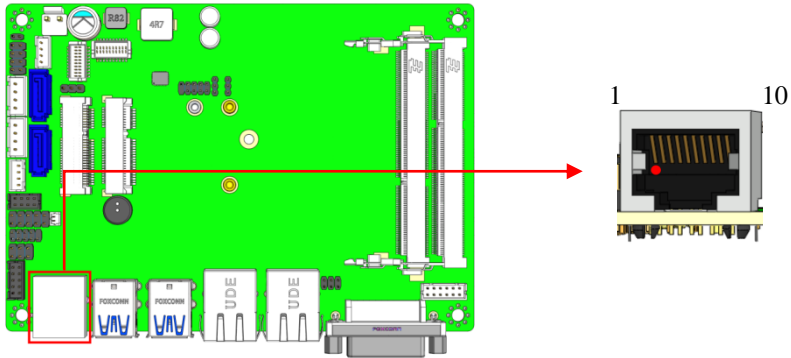

Signal Name	Pin #	Pin #	Signal Name
DSR#	1	2	GND
GND	3	4	GND
SSRX-	5	6	SSRX+
GND	7	8	SSTX-
SSTX+	9	10	

CN6: DVI-D Connector

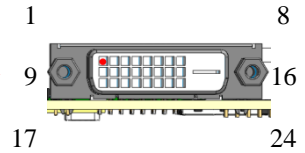
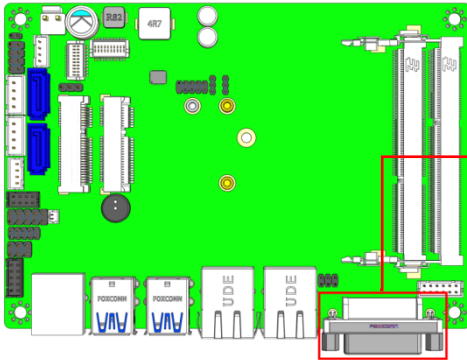

Signal Name	Pin #	Pin #	Signal Name
TMDS DAT2-	1	2	TMDS DAT2+
TMDS 2/4 SHIELD	3	4	TMDS DAT4-
TMDS DAT4+	5	6	DDC CLOCK
DDC DATA	7	8	ANALOG VSYNC
TMDS DAT1-	9	10	TMDS DAT1+
TMDS 1/3 SHIELD	11	12	TMDS DAT3-
TMDS DAT3+	13	14	+5V POWER
GND (for +5V)	15	16	HOT PLUG DET
TMDS DAT0-	17	18	TMDS DAT0+
TMDS 0/5 SHIELD	19	20	TMDS DAT5-
TMDS DAT5+	21	22	TMDS CLK SHIELD
TMDS CLOCK+	23	24	TMDS CLOCK-

INSTALLATIONS

CN7: Micro SD Connector (On Bottom Side)

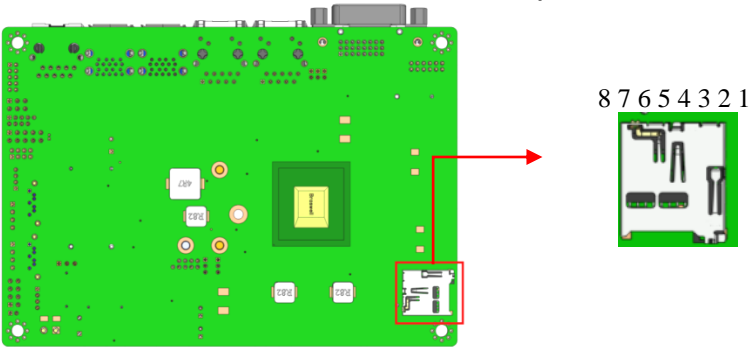

Pin #	Signal Name
1	DAT2
2	CD/DAT3
3	CMD
4	VDD
5	CLK
6	VSS
7	DAT0
8	DAT1

J1: Power Input Connector

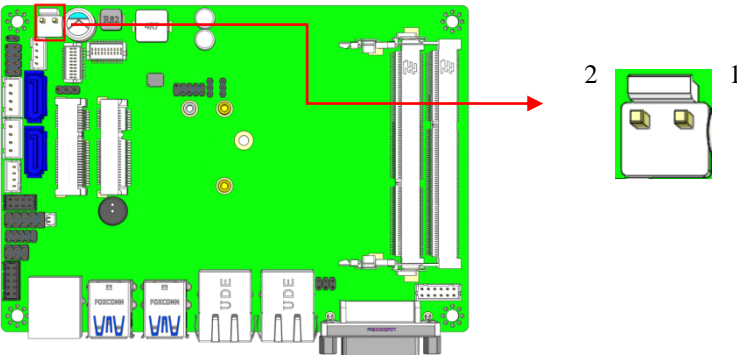

Pin #	Signal Name
1	POWER+
2	GND

J2/J5: Dual Channel LVDS Connector

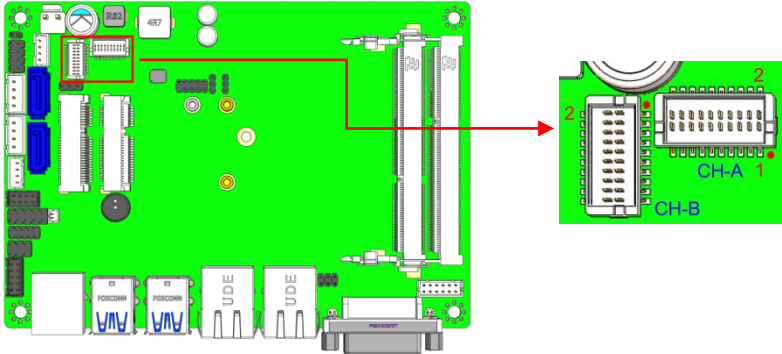

J2 (Channel A) Pin Assignment

Signal Name	Pin #	Pin #	Signal Name
LVDS_SAO_P	1	2	LVDS_SAO_N
GND	3	4	GND
LVDS_SBO_P	5	6	LVDS_SBO_N
GND	7	8	GND
LVDS_SCO_P	9	10	LVDS_SCO_N
GND	11	12	GND
LVDS_SCKO_P	13	14	LVDS_SCKO_N
GND	15	16	GND
LVDS_SDO_P	17	18	LVDS_SDO_N
VDD	19	20	VDD

J5 (Channel B) Pin Assignment

Signal Name	Pin #	Pin #	Signal Name
LVDS_SAE_P	1	2	LVDS_SAE_N
GND	3	4	GND
LVDS_SBE_P	5	6	LVDS_SBE_N
GND	7	8	GND
LVDS_SCE_P	9	10	LVDS_SCE_N
GND	11	12	GND
LVDS_SCKE_P	13	14	LVDS_SCKE_N
GND	15	16	GND
LVDS_SDE_P	17	18	LVDS_SDE_N
VDD	19	20	VDD

*** J2 /J5 connector model: HIROSE DF20G-20DP-1V(56) ***

J3: Backlight LCD Panel Power Connector

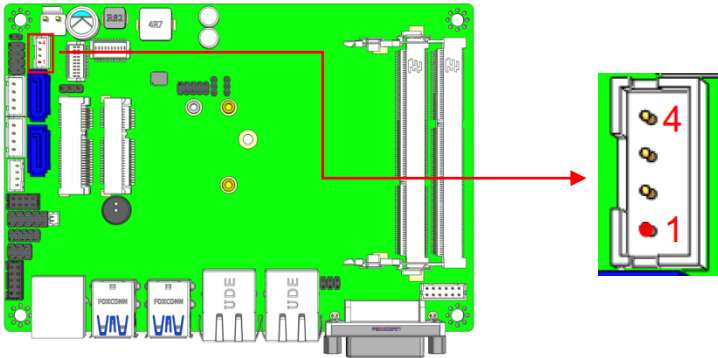

Pin #	Signal Name
1	VCC12
2	LVDS_BLON#
3	BKL_CTRL
4	GND

J4: Front Panel Pin Header

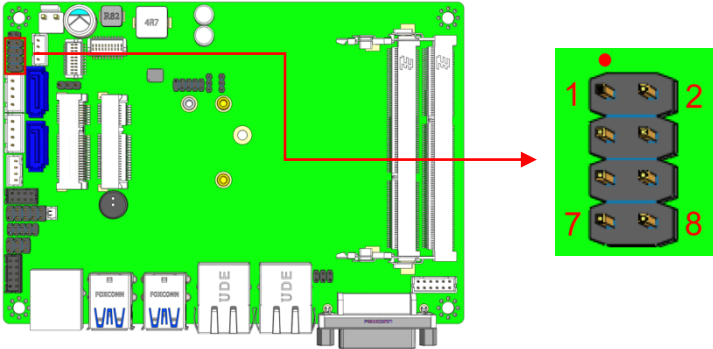

Signal Name	Pin #	Pin #	Signal Name
POWER BUTTON -	1	2	POWER BUTTON +
HDD LED +	3	4	HDD LED -
RESET BUTTON -	5	6	RESET BUTTON +
POWER LED +	7	8	POWER LED -

J6: SPI Flash Burn-in Pin Header

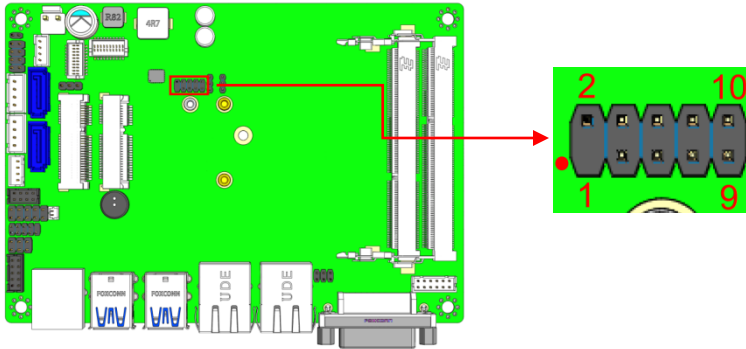

Signal Name	Pin #	Pin #	Signal Name
-		2	NC
SPI CS	3	4	+1.8V
SPI SO	5	6	SPI HOLD#
SPI WP#	7	8	SPI CLK
GND	9	10	SPI SI

J7/J12: Serial ATA III Connectors

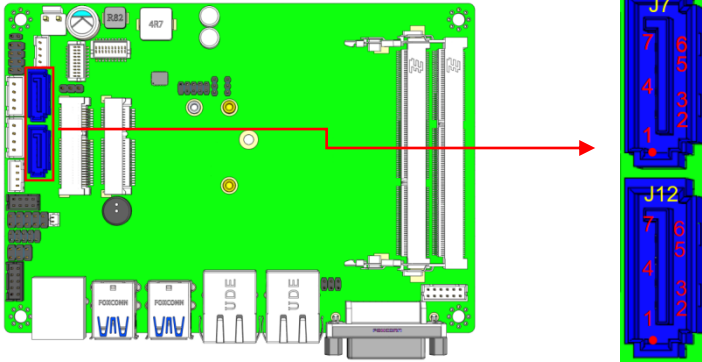

Pin #	Signal Name
1	GND
2	TXP0
3	TXN0
4	GND
5	RXN0
6	RXP0
7	GND

J8/J9: SATA HDD Power Connectors

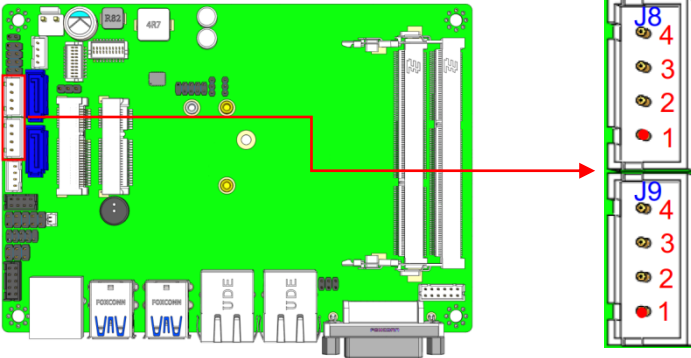

Pin #	Signal Name
1	+5V
2	GND
3	GND
4	+12V

J10: Half-sized Mini PCIe Sockets

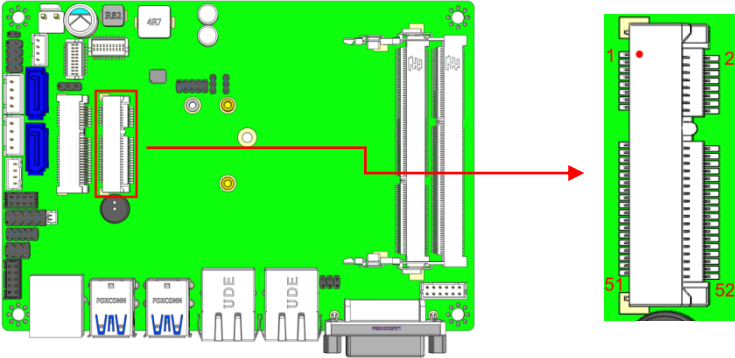

J11: Full-sized Mini PCIe Socket

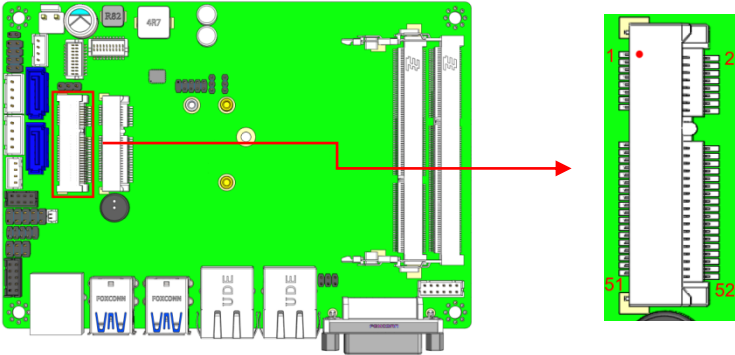

INSTALLATIONS

Signal Name	Pin #	Pin #	Signal Name
WAKE#	1	2	3.3V_AUX
COEX1	3	4	GND
COEX2	5	6	+1.5V
CLKREQ#	7	8	UIM_PWR
GND	9	10	UIM_DATA
REFCLK-	11	12	UIM_CLK1
REFCLK+	13	14	UIM_RESET
GND	15	16	UIM_CLK2
RSVD3	17	18	GND
RSVD4	19	20	W_DISABLE
PER_N0	21	22	PERST#
PER_P0	23	24	3.3V_AUX
GND	25	26	GND
GND	27	28	+1.5V
PET_N0	29	30	SMB_CLK
PET_P0	31	32	SMB_DAT
GND	33	34	GND
GND	35	36	USB_D-
3.3V_AUX	37	38	USB_D+
3.3V_AUX	39	40	GND
GND	41	42	LED_WWAN#
RSVD8	43	44	LED_WLAN#
RSVD9	45	46	LED_WPAN#
RSVD10	47	48	+1.5V
RSVD11	49	50	GND
RSVD12	51	52	3.3V_AUX

J13/J14: DDRIII SO-DIMM Sockets

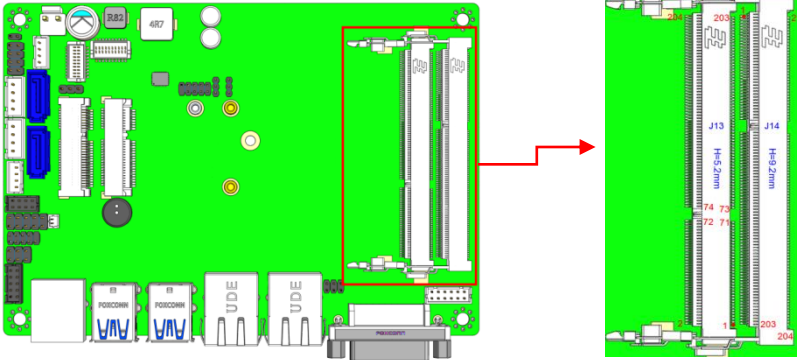

1	V _{REFDQ}	2	V _{SS}	53	DQ19	54	V _{SS}	105	V _{DD}	106	V _{DD}	155	V _{SS}	156	V _{SS}
3	V _{SS}	4	DQ4	55	V _{SS}	56	DQ28	107	A10/AP	108	BA1	157	DQ42	158	DQ46
5	DQ0	6	DQ5	57	DQ24	58	DQ29	109	BA0	110	RAS*	159	DQ43	160	DQ47
7	DQ1	8	V _{SS}	59	DQ25	60	V _{SS}	111	V _{DD}	112	V _{DD}	161	V _{SS}	162	V _{SS}
9	V _{SS}	10	DQS0	61	V _{SS}	62	DQS3	113	WE	114	SO	163	DQ48	164	DQ52
11	DM0	12	DQS0	63	DM3	64	DQS3	115	CAS	116	ODT0	165	DQ49	166	DQ53
13	V _{SS}	14	V _{SS}	65	V _{SS}	66	V _{SS}	117	V _{DD}	118	V _{DD}	167	V _{SS}	168	V _{SS}
15	DQ2	16	DQ6	67	DQ26	68	DQ30	119	A13/NC	120	ODT1	169	DQS6	170	DM6
17	DQ3	18	DQ7	69	DQ27	70	DQ31	121	ST	122	NC	171	DQS6	172	V _{SS}
19	V _{SS}	20	V _{SS}	71	V _{SS}	72	V _{SS}	123	V _{DD}	124	V _{DD}	173	V _{SS}	174	DQ54
21	DQ8	22	DQ12	73	CKE0	74	CKE1	125	NC	126	V _{REFCA}	175	DQ50	176	DQ55
23	DQ9	24	DQ13	75	V _{DD}	76	V _{DD}	127	V _{SS}	128	V _{SS}	177	DQ51	178	V _{SS}
25	V _{SS}	26	V _{SS}	77	NC	78	NC	129	DQ32	130	DQ36	179	V _{SS}	180	DQ60
27	DQST	28	DM1	79	BA2	80	NC	131	DQ33	132	DQ37	181	DQ56	182	DQ61
29	DQS1	30	RESET	81	V _{DD}	82	V _{DD}	133	V _{SS}	134	V _{SS}	183	DQ57	184	V _{SS}
31	V _{SS}	32	V _{SS}	83	A12/BC	84	A11	135	DQS4	136	DM4	185	V _{SS}	186	DQS7
33	DQ10	34	DQ14	85	A9	86	A7	137	DQS4	138	V _{SS}	187	DM7	188	DQS7
35	DQ11	36	DQ15	87	V _{DD}	88	V _{DD}	139	V _{SS}	140	DQ38	189	V _{SS}	190	V _{SS}
37	V _{SS}	38	V _{SS}	89	A8	90	A6	141	DQ34	142	DQ39	191	DQ58	192	DQ62
39	DQ16	40	DQ20	91	A5	92	A4	143	DQ35	144	V _{SS}	193	DQ59	194	DQ63
41	DQ17	42	DQ21	93	V _{DD}	94	V _{DD}	145	V _{SS}	146	DQ44	195	V _{SS}	196	V _{SS}
43	V _{SS}	44	V _{SS}	95	A3	96	A2	147	DQ40	148	DQ45	197	SA0	198	EVENT
45	DQS2	46	DM2	97	A1	98	A0	149	DQ41	150	V _{SS}	199	V _{DDSPD}	200	SDA
47	DQS2	48	V _{SS}	99	V _{DD}	100	V _{DD}	151	V _{SS}	152	DQS5	201	SA1	202	SCL
49	V _{SS}	50	DQ22	101	CK0	102	CK1	153	DM5	154	DQS5	203	V _{tt}	204	V _{tt}
51	DQ18	52	DQ23	103	CK0	104	CK1								

J15: MCU Burn-in Connector

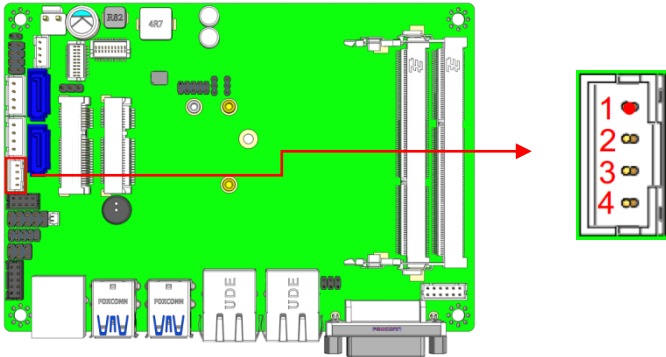

Pin #	Signal Name
1	3.3V
2	SBW_TCK
3	SBW_TDIO
4	GND

J16: Battery Connector

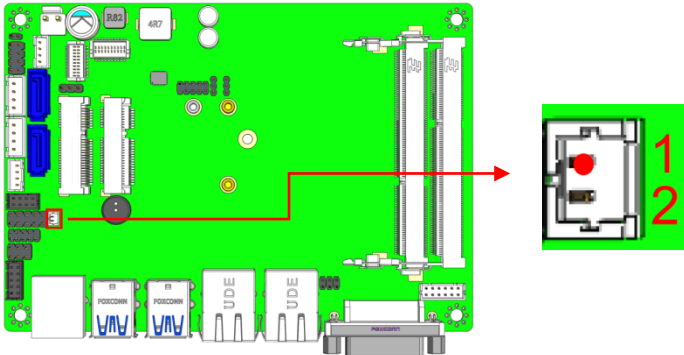

Pin #	Signal Name
1	BT+
2	GND

J17: Digital I/O Connector

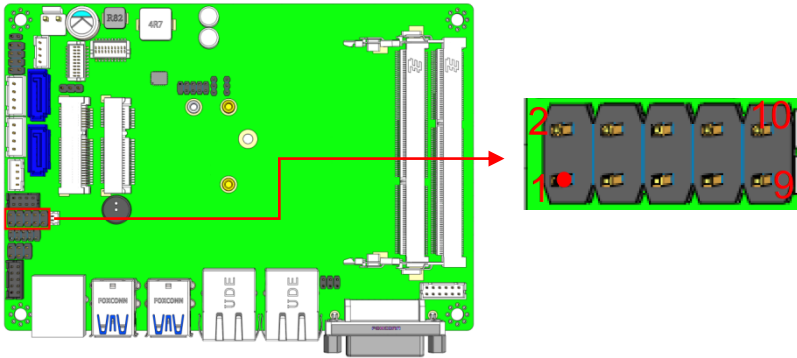

Signal Name	Pin #	Pin #	Signal Name
GND	1	2	+5V
OUT3	3	4	OUT1
OUT2	5	6	OUT0
IN3	7	8	IN1
IN2	9	10	IN0

J18: LPC Debug Connector

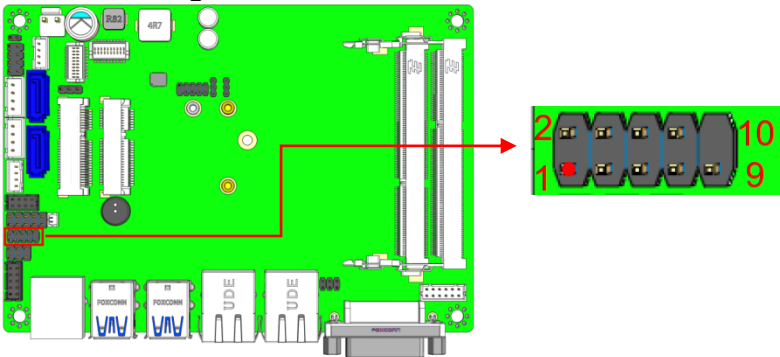

Signal Name	Pin #	Pin #	Signal Name
LPC AD0	1	2	RESET#
LPC AD1	3	4	LPC FRAME#
LPC AD2	5	6	+3.3V
LPC AD3	7	8	GND
LPC CLK	9	10	Empty Pin

INSTALLATIONS

J19: VGA Connector

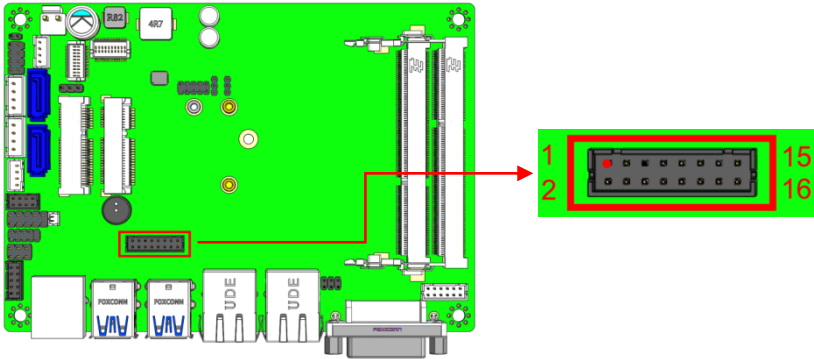

Signal Name	Pin #	Pin #	Signal Name
CRT RED	1	2	+5V
CRT GREEN	3	4	GND
CRT BLUE	5	6	NC
NC	7	8	DDC DATA
GND	9	10	CRT HSYNC
GND	11	12	CRT VSYNC
GND	13	14	DDC CLK
GND	15	16	NC

J20: COM2 Connector

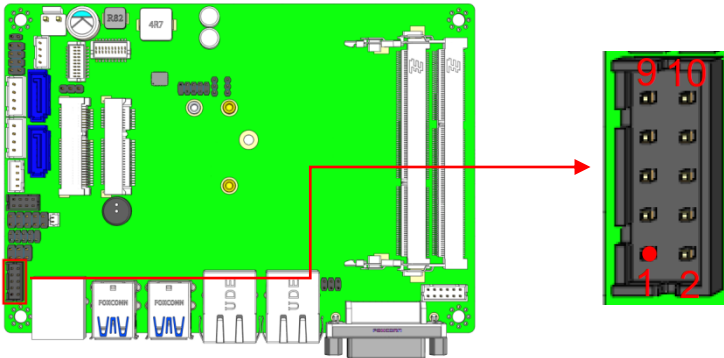

Signal Name	Pin #	Pin #	Signal Name
COM2 DCD#	1	2	COM2 RX
COM2 TX	3	4	COM2 DTR#
COM2 GND	5	6	COM2 DSR#
COM2 RTS#	7	8	COM2 CTS#
COM2 RI#	9	10	

J21: Audio Connector

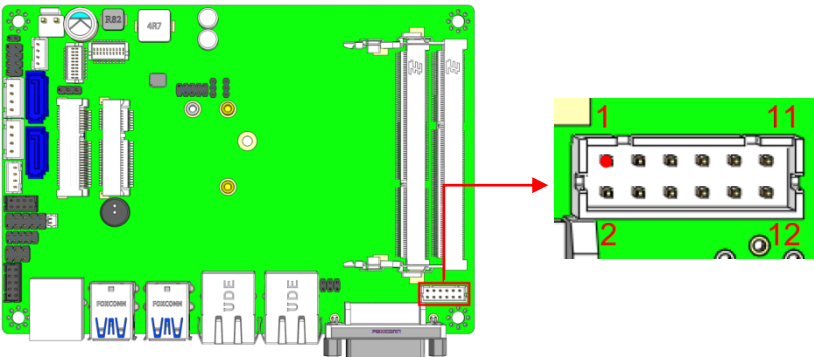

Signal Name	Pin #	Pin #	Signal Name
LINE-OUT LEFT	1	2	LINE-OUT RIGHT
LINE-OUT JACK DET	3	4	GND
LINE-IN LEFT	5	6	LINE-IN RIGHT
LINE-IN JACK DET	7	8	GND
MIC LEFT	9	10	MIC RIGHT
MIC JACK DET	11	12	GND

INSTALLATIONS

F_USB1: USB2.0 Connector

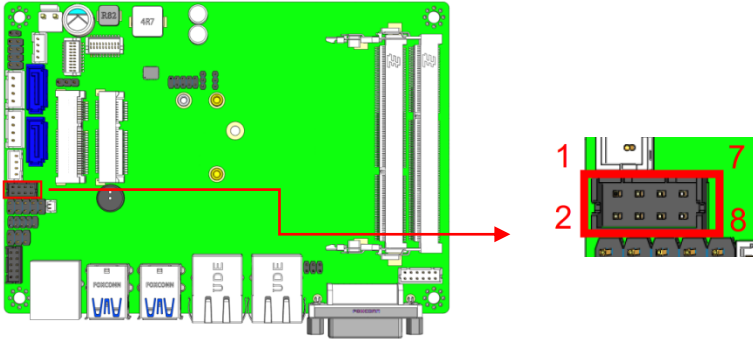

Signal Name	Pin #	Pin #	Signal Name
GND	2	1	+5V
USB2_P2D+	4	3	USB2_P1D-
USB2_P2D-	6	5	USB2_P1D+
+5V	8	7	GND

BIOS Setup

This chapter describes the different settings available in the AMI BIOS that comes with the board. The topics covered in this chapter are as follows:

BIOS Introduction	34
BIOS Setup	34
Advanced Settings	35
CSM Configuration	43
Chipset Settings	45
Security Settings	46
Boot Settings	47
Save & Exit Settings	48

BIOS Introduction

The BIOS (Basic Input/Output System) installed in your computer system's ROM supports Intel processors. The BIOS provides critical low-level support for a standard device such as disk drives, serial ports and parallel ports. It also password protection as well as special support for detailed fine-tuning of the chipset controlling the entire system.

BIOS Setup

The BIOS provides a Setup utility program for specifying the system configurations and settings. The BIOS ROM of the system stores the Setup utility. When you turn on the computer, the BIOS is immediately activated. Pressing the key immediately allows you to enter the Setup utility. If you are a little bit late pressing the key, POST (Power On Self Test) will continue with its test routines, thus preventing you from invoking the Setup. If you still wish to enter Setup, restart the system by pressing the "Reset" button or simultaneously pressing the <Ctrl>, <Alt> and <Delete> keys. You can also restart by turning the system Off and back On again. The following message will appear on the screen:

```
Press <DEL> to Enter Setup
```

In general, you press the arrow keys to highlight items, <Enter> to select, the <PgUp> and <PgDn> keys to change entries, <F1> for help and <Esc> to quit.

When you enter the Setup utility, the Main Menu screen will appear on the screen. The Main Menu allows you to select from various setup functions and exit choices.

Warning: *It is strongly recommended that you avoid making any changes to the chipset defaults. These defaults have been carefully chosen by both AMI and your system manufacturer to provide the absolute maximum performance and reliability. Changing the defaults could cause the system to become unstable and crash in some cases.*

Main Settings

Aptio Setup Utility					
Main	Advanced	Chipset	Boot	Security	Save & Exit
System Language			[English]		→ ← Select Screen ↑ ↓ Select Item Enter: Select +- Change Opt F1: General Help F2: Previous Values F3: Optimized Default F4: Save & EXIT ESC: Exit
System Date			[Wed 12/09/2015]		
System Time			[10:40:30]		

System Date

Set the Date. Use Tab to switch between Data elements.

System Time

Set the Time. Use Tab to switch between Data elements.

Advanced Settings

Aptio Setup Utility					
Main	Advanced	Chipset	Boot	Security	Save & Exit
	<ul style="list-style-type: none"> ▶ Trusted Computing ▶ ACPI Settings ▶ LVDS1 (eDP/DP) Configuration ▶ iSmart Controller ▶ NCT5523D Super IO Configuration ▶ NCT5523D H/W Monitor ▶ PPM Configuration ▶ SATA Configuration ▶ Miscellaneous Configuration ▶ CSM Configuration ▶ USB Configuration 				→ ← Select Screen ↑ ↓ Select Item Enter: Select +- Change Opt F1: General Help F2: Previous Values F3: Optimized Default F4: Save & EXIT ESC: Exit

ACPI Settings

Aptio Setup Utility

Main	Advanced	Chipset	Boot	Security	Save & Exit
ACPI Settings					
Enable ACPI Auto Configuration			Disable		→ ← Select Screen ↑ ↓ Select Item Enter: Select +- Change Field F1: General Help F2: Previous Values F3: Optimized Default F4: Save ESC: Exit
Enable Hibernation			Enabled		
ACPI Sleep State			S3 (Suspend to R...)		
Lock Legacy Resources			Disable		

Enable ACPI Auto Configuration

Enables or Disables BIOS ACPI Auto Configuration.

Enable Hibernation

Enables or Disables System ability to Hibernate (OS/S4 Sleep State). This option may be not effective with some OS.

ACPI Sleep State

Select the highest ACPI sleep state the system will enter when the SUSPEND button is pressed.

Lock Legacy Resources

Enables or Disables Lock of Legacy Resources

LVDS (eDP/DP) Configuration

Aptio Setup Utility

Main	Advanced	Chipset	Boot	Security	Save & Exit
LVDS (eDP/DP) Configuration					→ ← Select Screen ↑ ↓ Select Item Enter: Select +- Change Field F1: General Help F2: Previous Values F3: Optimized Default F4: Save ESC: Exit
LVDS (eDP/DP) Support		Disabled			

LVDS (eDP/DP) Support

LVDS (eDP/DP) ON/OFF

iSmart Controller

Aptio Setup Utility

Main	Advanced	Chipset	Boot	Security	Save & Exit
iSmart Controller					→ ← Select Screen ↑ ↓ Select Item Enter: Select +- Change Opt. F1: General Help F2: Previous Values F3: Optimized Defaults F4: Save & Exit ESC: Exit
Power-On after Power failure		Disable			
Temperature Guardian		Disable			
Schedule Slot 1		None			
Schedule Slot 2		None			

Power-On after Power failure

This field sets the system power status whether Disable or Enable when power returns to the system from a power failure situation.

Temperature Guardian

Generate the reset signal when system hangs up on POST.

Schedule Slot 1 / 2

Setup the hour/minute for system power on.

NCT5523D Super IO Configuration

Aptio Setup Utility

Main	Advanced	Chipset	Boot	Security	Save & Exit
NCT5523D Super IO Configuration					→ ← Select Screen ↑ ↓ Select Item Enter: Select +- Change Field F1: General Help F2: Previous Values F3: Optimized Default F4: Save ESC: Exit
Super IO Chip		NCT5523D			
▶ Serial Port 1 Configuration					
▶ Serial Port 2 Configuration					

Serial Port Configuration

Set Parameters of Serial Ports (COM)

NCT5523D H/W Monitor

Aptio Setup Utility

Main	Advanced	Chipset	Boot	Security	Save & Exit
PC Health Status					→ ← Select Screen ↑ ↓ Select Item Enter: Select +- Change Field F1: General Help F2: Previous Values F3: Optimized Default F4: Save ESC: Exit
ACPI Shutdown Temperature		Disable			
System Temperature		+39.0 C			
CPU Temperature		+39.5 C			
Vcore		+0.872 V			
VCC3V		+3.360 V			
3VSB		+3.120V			

Temperatures/Voltages

These fields are the parameters of the hardware monitoring function feature of the board. The values are read-only values as monitored by the system and show the PC health status.

INSTALLATIONS

PPM Configuration

Aptio Setup Utility

Main	Advanced	Chipset	Boot	Security	Save & Exit
PPM Configuration					
EIST			Enable		→ ← Select Screen ↑ ↓ Select Item Enter: Select +- Change Field F1: General Help F2: Previous Values F3: Optimized Default F4: Save ESC: Exit

EIST

Enable / Disable Intel SpeedStep

SATA Configuration

Aptio Setup Utility

Main	Advanced	Chipset	Boot	Security	Save & Exit
	SATA Controller		Enabled		
	SATA Mode Selection		AHCI		
	SATA Interface Speed		Gen3		
	SATA Port 0				→ ← Select Screen
	Not Present				↑ ↓ Select Item
	Port 0		Enabled		Enter: Select
	SATA Port 1				+ - Change Field
	Not Present				F1: General Help
	Port 1		Enabled		F2: Previous Values
					F3: Optimized Default
					F4: Save
					ESC: Exit

SATA Controller

Enable / Disable SATA Device

SATA Mode Selection

Determines how SATA controller operates.

SATA Interface Speed

Select SATA Interface Speed CHV A1 always with Gen1 Speed.

Port

Enable or Disable SATA Port

Hot Plug

Designates this port as Hot Pluggable.

INSTALLATIONS

Miscellaneous Configuration

Aptio Setup Utility

Main	Advanced	Chipset	Boot	Security	Save & Exit
Miscellaneous		Leagacy System		→ ← Select Screen ↑ ↓ Select Item Enter: Select +- Change Opt F1: General Help F2: Previous Values F3: Optimized Default F4: Save & EXIT ESC: Exit	

Miscellaneous

BOM Config

CSM Configuration

Aptio Setup Utility

Main	Advanced	Chipset	Boot	Security	Save & Exit
Compatibility Support Module Configuration					
	CSM Support		Enabled		
	CSM16 Module Version		07.76		
	GateA20 Active		Upon Request		
	Option ROM Messages		Force BIOS		
	Boot option filter		UEFI and Legacy		
	Option ROM execution				→ ← Select Screen ↑ ↓ Select Item Enter: Select +- Change Field F1: General Help F2: Previous Values F3: Optimized Default F4: Save ESC: Exit
	Network		Do not launch		
	Storage		UEFI		
	Video		Legacy		
	Other PCI device		UEFI		

CSM Support

Enable/Disable CSM Support.

Boot option filter

This option controls Legacy/UEFI ROMs priority

Network

Controls the execution of UEFI and Legacy PXE OpROM

Storage

Controls the execution of UEFI and Legacy Storage OpROM

Video

Controls the execution of UEFI and Legacy Video OpROM

Other PCI device

Determines OpROM execution policy for devices other than Network, Storage, or Video.

USB Configuration

Aptio Setup Utility

Main	Advanced	Chipset	Boot	Security	Save & Exit
USB Configuration					
USB Module Version			11		
USB Controllers:					
1XHCI					
USB Devices:					
1 Drive, 1 Keyboard, 1 Hubs					
Legacy USB Support			Enabled		
XHCI Hand-off			Enabled	→ ← Select Screen	
USB Mass Storage Driver Support			Enabled	↑ ↓ Select Item	
USB hardware delays and time-outs:					
USB Transfer time-out			20 sec	Enter: Select	
Device reset time-out			20 sec	+- Change Field	
Device power-up delay			Auto	F1: General Help	
F2: Previous Values					
F3: Optimized Default					
F4: Save					
ESC: Exit					

Legacy USB Support

Enables Legacy USB support.

AUTO option disables legacy support if no USB devices are connected.

DISABLE option keeps USB devices available only for EFI applications.

XHCI Hand-off

This is a workaround for OSes without XHCI hand-off support. The XHCI ownership change should be claimed by XHCI driver.

USB Mass Storage Driver Support

Enable/Disable USB Mass Storage Driver Support.

USB Transfer time-out

The time-out value for Control, Bulk, and Interrupt transfers.

Device reset time-out

USB mass Storage device start Unit command time-out.

Device power-up delay

Maximum time the device will take before it properly reports itself to the Host Controller. 'Auto' uses default value: for a Root port it is 100ms, for a Hub port the delay is taken from Hub descriptor.

Chipset Settings

Aptio Setup Utility

Main	Advanced	Chipset	Boot	Security	Save & Exit
<ul style="list-style-type: none"> ▶ North Bridge ▶ South Bridge 					

North Bridge

Aptio Setup Utility

Main	Advanced	Chipset	Boot	Security	Save & Exit
Memory Information					→ ← Select Screen ↑ ↓ Select Item Enter: Select +- Change Field F1: General Help F2: Previous Values F3: Optimized Default F4: Save ESC: Exit
Total Memory		8192 MB(LPDDR3)			
Memory Slot 0		4096 MB(LPDDR3)			
Memory Slot 1		4096 MB(LPDDR3)			
Max TOLUD		Dynamic			

South Bridge

Aptio Setup Utility

Main	Advanced	Chipset	Boot	Security	Save & Exit
<ul style="list-style-type: none"> ▶ Security Configuration ▶ Azalia Configuration 					
Restore AC Power Loss			Power off		

Azalia Configuration

Azalia HD Audio Options

USB Configuration

USB Configuration Settings

PCI Express Configuration

PCI Express Configuration Settings

Azalia Configuration

Main	Advanced	Chipset	Boot	Security	Save & Exit
Azalia Configuration					
Audio Controller			Enabled		

Audio Controller

Control Detection of the Azalia device.

Disable= Azalia will be unconditionally disabled.

Enable= Azalia will be unconditionally Enable.

Security Settings

This section allows you to configure and improve your system and allows you to set up some system features according to your preference.

Aptio Setup Utility

Main	Advanced	Chipset	Boot	Security	Save & Exit
Password Description					
If ONLY the Administrator's password is set, then this only limit access to Setup and is only asked for when entering Setup.					
If ONLY the User's password is set, then this is a power on password and must be entered to boot or enter Setup. In Setup the User will have Administrator rights					
The password length must be					→ ← Select Screen
in the following range:					↑ ↓ Select Item
Minimum length			3	Enter: Select	+ - Change Field
Maximum length			20	F1: General Help	F2: Previous Values
Administrator Password					F3: Optimized Default
User Password					F4: Save
					ESC: Exit

Administrator Password

Set Setup Administrator Password.

User Password

Set User Password.

Boot Settings

This section allows you to configure the boot settings.

Aptio Setup Utility					
Main	Advanced	Chipset	Boot	Security	Save & Exit
Boot Configuration					
Setup Prompt Timeout		1			
Bootup NumLock State		Off			
Fast Boot		Disabled			
Quiet Boot		Disabled			
Boot Option Priorities					
New Boot Option Policy		Default			
Boot mode select		UEFI			
FIX BOOT ORDER Priorities					
Boot Option #1		Hard Disk			
Boot Option #2		CD/DVD			
Boot Option #3		USB Hard Disk			→ ← Select Screen
Boot Option #4		USB CD/DVD			↑ ↓ Select Item
Boot Option #5		USB Key			Enter: Select
Boot Option #6		USB Floppy			+ - Change Field
Boot Option #7		USB Lan			F1: General Help
Boot Option #8		Network			F2: Previous Values
					F3: Optimized Default
					F4: Save
					ESC: Exit

Setup Prompt Timeout

Number of seconds to wait for setup activation key.

65535(0xFFFF) means indefinite waiting.

Bootup NumLock State

Select the keyboard NumLock state.

Quiet Boot

Enables/Disables Quiet Boot option.

Fast Boot

Enables/Disables boot with initialization of a minimal set of devices required to launch active boot option. Has no effect for BBS boot options.

Save & Exit Settings

Aptio Setup Utility

Main	Advanced	Chipset	Boot	Security	Save & Exit
Reset System with ME disable ModeMEUD000					
Save Options					
Save Changes and Exit					
Discard Changes and Exit					
Save Changes and Reset					
Discard Changes and Reset					
Save Changes					
Discard Changes					
Defaults Options					
Restore Defaults					
Save as User Defaults					
Restore User Defaults					
					→ ← Select Screen
					↑ ↓ Select Item
					Enter: Select
					+ - Change Field
					F1: General Help
					F2: Previous Values
					F3: Optimized Default
					F4: Save
					ESC: Exit

Save Changes and Exit

Exit system setup after saving the changes.

Discard Changes and Exit

Exit system setup without saving any changes.

Save Changes and Reset

Reset the system after saving the changes.

Discard Changes and Reset

Reset system setup without saving any changes.

Save Changes

Save Changes done so far to any of the setup options.

Discard Changes

Discard Changes done so far to any of the setup options.

Restore Defaults

Restore/Load Defaults values for all the setup options.

Save as User Defaults

Save the changes done so far as User Defaults.

Restore User Defaults

Restore the User Defaults to all the setup options.

Drivers Installation

This section describes the installation procedures for software and drivers. The software and drivers are included with the motherboard. If you find the items missing, please contact the vendor where you made the purchase. The contents of this section include the following:

Intel Chipset Software Installation Utility.....	50
VGA Drivers Installation	53
Realtek HD Audio Driver Installation	55
LAN Drivers Installation	56
TXE Drivers Installation.....	59

IMPORTANT NOTE:

After installing your Windows operating system, you must install first the Intel Chipset Software Installation Utility before proceeding with the drivers installation.

Intel Chipset Software Installation Utility

The Intel Chipset Drivers should be installed first before the software drivers to enable Plug & Play INF support for Intel chipset components. Follow the instructions below to complete the installation.

1. Insert the disc that comes with the board. Click *Intel* and then *Intel(R) Braswell Chipset Drivers*.



2. Click *Intel(R) Chipset Software Installation Utility*



3. When the Welcome screen to the Intel® Chipset Device Software appears, click *Next* to continue.



4. Click **Accept** to accept the software license agreement and proceed with the installation process.



5. On the Readme File Information screen, click **Install** to continue the installation.

6. The Setup process is now complete. Click **Finish** to restart the computer and for changes to take effect.

VGA Drivers Installation

1. Click *Intel(R) Braswell Graphics Driver*



2. When the Welcome screen appears, click *Next* to continue.

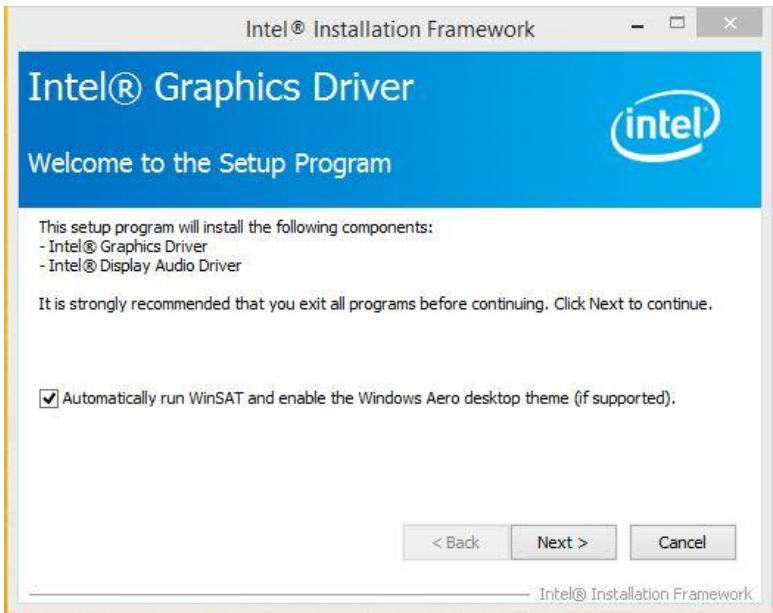

3. Click *Yes* to to agree with the license agreement and continue the installation.

4. On the Readme File Information screen, click *Next* to continue the installation of the Intel® Graphics Driver.

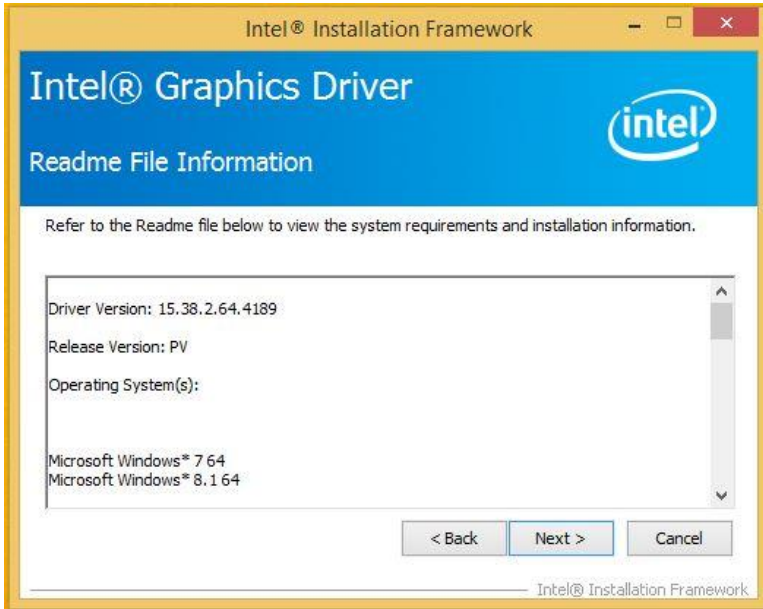

5. On Setup Progress screen, click *Next* to continue.

6. Setup complete. Click *Finish* to restart the computer and for changes to take effect.

Realtek HD Audio Driver Installation

1. Click *Realtek High Definition Audio Driver*.



2. On the Welcome to the InstallShield Wizard screen, click *Next* to proceed with and complete the installation process.

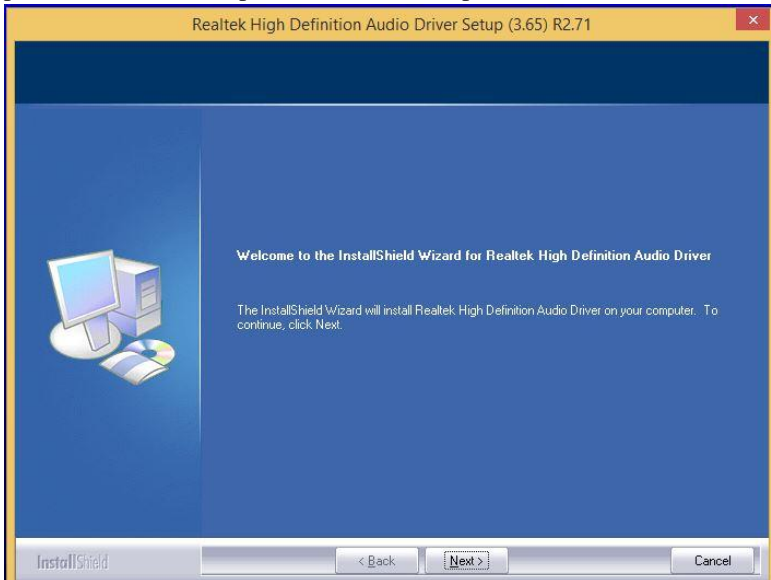

3. Restart the computer when prompted.

LAN Drivers Installation

1. Insert the CD that comes with the board. Click *LAN Card* and then *Intel LAN Controller Drivers*.



2. Click *Intel(R) I21x Gigabit Network Drivers*



3. In the Welcome screen, click *Next*.

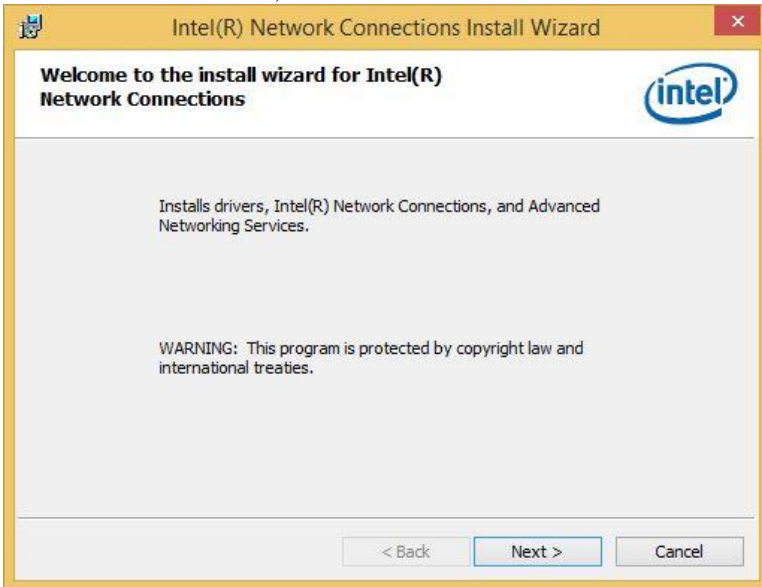

4. In the License Agreement screen, click **I accept the terms in license agreement** and **Next** to accept the software license agreement and proceed with the installation process.



5. Click the checkbox for **Drivers** in the Setup Options screen to select it and click **Next** to continue.

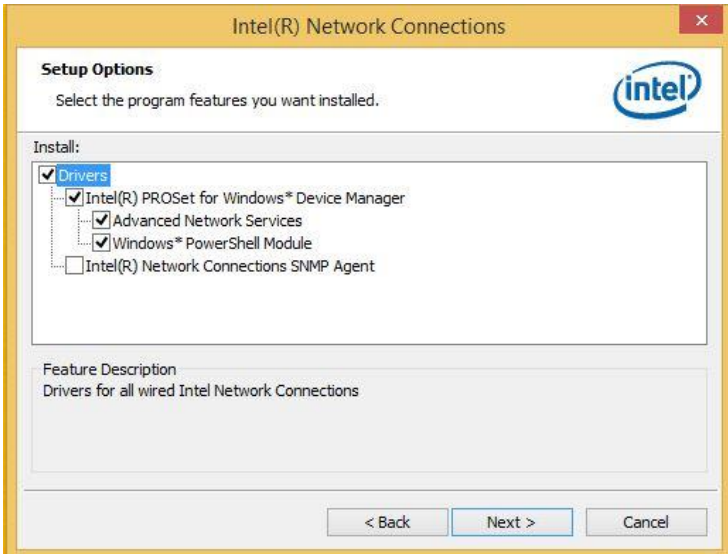

6. When the Ready to Install the Program screen appears, click **Install** to continue.



7. When InstallShield Wizard is complete, click **Finish**.

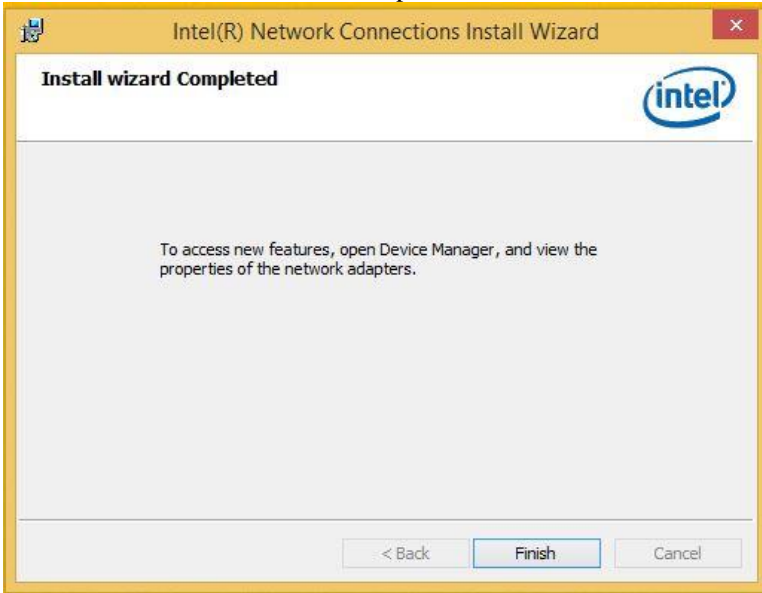

TXE Drivers Installation

1. Click *Intel(R) TXE Driver*



2. When the Welcome screen appears, click *Next* to continue.

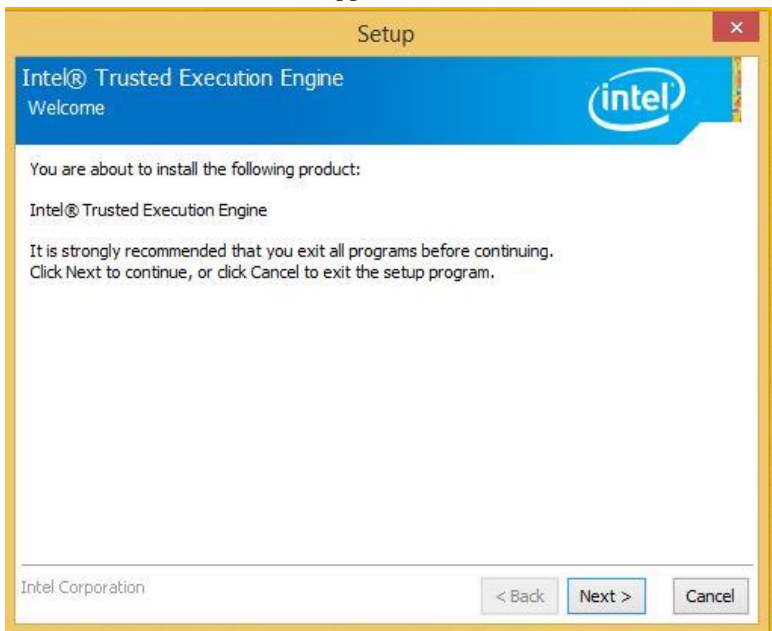

DRIVERS INSTALLATION

3. Click *Next* to to agree with the license agreement and continue the installation.
4. On the Confirmation screen, click *Next* to continue the installation of the Intel(R) TXE Driver.
5. Setup complete. Click *Finish* to restart the computer and for changes to take effect.

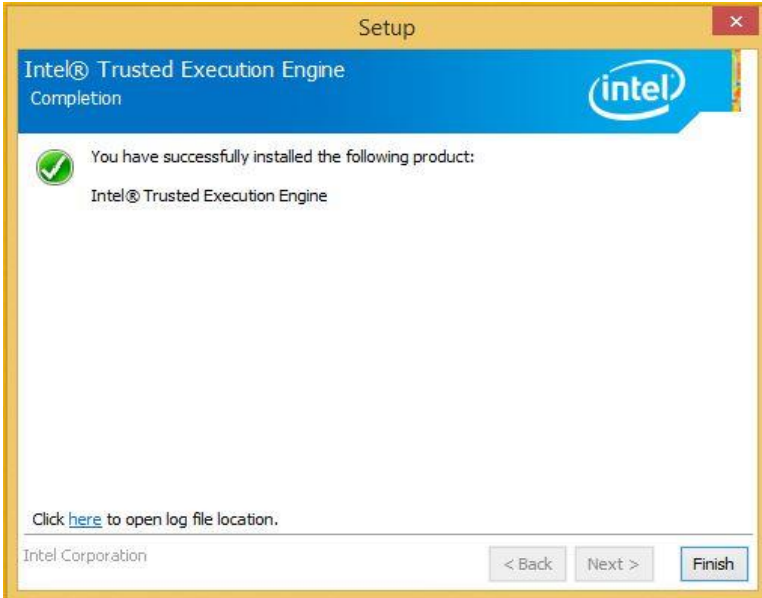

Appendix

A. I/O Port Address Map

Each peripheral device in the system is assigned a set of I/O port addresses that also becomes the identity of the device. The following table lists the I/O port addresses used.

Address	Device Description
000h - FFFh	PCI Express Standard Root Port
040h - 043h	System timer
070h - 077h	System CMOS/real time clock
D00h - FFFh	PCI Bus
2F8h - 2FFh	Communications Port (COM2)
3B0h - 3BBh	Intel(R) HD Graphics
3F8h - 3FFh	Communications Port (COM1)
040h - 05Fh	Intel(R) Celeron(R)/Pentium(R) SM Bus Controller
060h - 07Fh	Standard SATA AHCI Controller

B. Interrupt Request Lines (IRQ)

Peripheral devices use interrupt request lines to notify CPU for the service required. The following table shows the IRQ used by the devices on board.

Level	Function
IRQ0	System timer
IRQ3	Communications Port (COM2)
IRQ4	Communications Port (COM1)
IRQ10	Intel(R) Celeron(R)/Pentium(R) SM Bus Controller
IRQ 18	Intel(R) Atom(TM)/Celeron(R)/Pentium(R) Processor SD Host Controller
IRQ19	Standard SATA AHCI Controller
IRQ22	High Definition Audio Controller

C. Watchdog Timer Configuration

The WDT is used to generate a variety of output signals after a user programmable count. The WDT is suitable for use in the prevention of system lock-up, such as when software becomes trapped in a deadlock. Under these sorts of circumstances, the timer will count to zero and the selected outputs will be driven. Under normal circumstance, the user will restart the WDT at regular intervals before the timer counts to zero.

SAMPLE CODE:

```
File of the NCT5523D.H
//-----
//
// THIS CODE AND INFORMATION IS PROVIDED "AS IS" WITHOUT WARRANTY OF ANY
// KIND, EITHER EXPRESSED OR IMPLIED, INCLUDING BUT NOT LIMITED TO THE
// IMPLIED WARRANTIES OF MERCHANTABILITY AND/OR FITNESS FOR A PARTICULAR
// PURPOSE.
//
//-----
#ifndef __NCT5523D_H
#define __NCT5523D_H      1
//-----
#define NCT5523D_INDEX_PORT      (NCT5523D_BASE)
#define NCT5523D_DATA_PORT      (NCT5523D_BASE+1)
//-----
#define NCT5523D_REG_LD          0x07
//-----
#define NCT5523D_UNLOCK          0x87
#define NCT5523D_LOCK           0xAA
//-----
unsigned int Init_NCT5523D(void);
void Set_NCT5523D_LD( unsigned char);
void Set_NCT5523D_Reg( unsigned char, unsigned char);
unsigned char Get_NCT5523D_Reg( unsigned char);
//-----
#endif      //__NCT5523D_H
```

APPENDIX

File of the MAIN.CPP.

```
//-----  
//  
// THIS CODE AND INFORMATION IS PROVIDED "AS IS" WITHOUT WARRANTY OF ANY  
// KIND, EITHER EXPRESSED OR IMPLIED, INCLUDING BUT NOT LIMITED TO THE  
// IMPLIED WARRANTIES OF MERCHANTABILITY AND/OR FITNESS FOR A PARTICULAR  
// PURPOSE.  
//  
//-----  
#include <dos.h>  
#include <conio.h>  
#include <stdio.h>  
#include <stdlib.h>  
#include "NCT5523D.H"  
//-----  
int main (void);  
  
void WDTInitial(void);  
void WDTEnable(unsigned char);  
void WDTDisable(void);  
  
//-----  
int main (void)  
{  
    char SIO;  
  
    SIO = Init_NCT5523D();  
    if (SIO == 0)  
    {  
        printf("Can not detect Nuvoton NCT5523D, program abort.\n");  
        return(1);  
    }  
  
    WDTInitial();  
  
    WDTEnable(10);  
  
    WDTDisable();  
  
    return 0;  
}  
//-----  
void WDTInitial(void)  
{  
    unsigned char bBuf;  
    Set_NCT5523D_LD(0x08);                               //switch to logic device 8  
    bBuf = Get_NCT5523D_Reg(0x30);  
    bBuf &= (~0x01);  
    Set_NCT5523D_Reg(0x30, bBuf);                       //Enable WDTO  
}  
//-----
```

```
void WDTEnable(unsigned char NewInterval)
{
    unsigned char bBuf;

    Set_NCT5523D_LD(0x08);           //switch to logic device 8
    Set_NCT5523D_Reg(0x30, 0x01);    //enable timer

    bBuf = Get_NCT5523D_Reg(0xF0);
    bBuf &= (~0x08);
    Set_NCT5523D_Reg(0xF0, bBuf);    //count mode is second

    Set_NCT5523D_Reg(0xF1, NewInterval); //set timer
}
//-----
void WDTDisable(void)
{
    Set_NCT5523D_LD(0x08);           //switch to logic device 8
    Set_NCT5523D_Reg(0xF1, 0x00);    //clear watchdog timer
    Set_NCT5523D_Reg(0x30, 0x00);    //watchdog disabled
}
//-----
```

APPENDIX

File of the NCT5523D.CPP

```
//-----  
//  
// THIS CODE AND INFORMATION IS PROVIDED "AS IS" WITHOUT WARRANTY OF ANY  
// KIND, EITHER EXPRESSED OR IMPLIED, INCLUDING BUT NOT LIMITED TO THE  
// IMPLIED WARRANTIES OF MERCHANTABILITY AND/OR FITNESS FOR A PARTICULAR  
// PURPOSE.  
//  
//-----  
#include "NCT5523D.H"  
#include <dos.h>  
//-----  
unsigned int NCT5523D_BASE;  
void Unlock_NCT5523D (void);  
void Lock_NCT5523D (void);  
//-----  
unsigned int Init_NCT5523D(void)  
{  
    unsigned int result;  
    unsigned char ucDid;  
  
    NCT5523D_BASE = 0x4E;  
    result = NCT5523D_BASE;  
  
    ucDid = Get_NCT5523D_Reg(0x20);  
    if (ucDid == 0xC4) //NCT5523D??  
    { goto Init_Finish; }  
  
    NCT5523D_BASE = 0x2E;  
    result = NCT5523D_BASE;  
  
    ucDid = Get_NCT5523D_Reg(0x20);  
    if (ucDid == 0xC4) //NCT5523D??  
    { goto Init_Finish; }  
  
    NCT5523D_BASE = 0x00;  
    result = NCT5523D_BASE;  
  
Init_Finish:  
    return (result);  
}  
//-----  
void Unlock_NCT5523D (void)  
{  
    outportb(NCT5523D_INDEX_PORT, NCT5523D_UNLOCK);  
    outportb(NCT5523D_INDEX_PORT, NCT5523D_UNLOCK);  
}  
//-----  
void Lock_NCT5523D (void)  
{  
    outportb(NCT5523D_INDEX_PORT, NCT5523D_LOCK);  
}  
//-----
```

```
void Set_NCT5523D_LD( unsigned char LD)
{
    Unlock_NCT5523D();
    outputb(NCT5523D_INDEX_PORT, NCT5523D_REG_LD);
    outputb(NCT5523D_DATA_PORT, LD);
    Lock_NCT5523D();
}
//-----
void Set_NCT5523D_Reg( unsigned char REG, unsigned char DATA)
{
    Unlock_NCT5523D();
    outputb(NCT5523D_INDEX_PORT, REG);
    outputb(NCT5523D_DATA_PORT, DATA);
    Lock_NCT5523D();
}
//-----
unsigned char Get_NCT5523D_Reg(unsigned char REG)
{
    unsigned char Result;
    Unlock_NCT5523D();
    outputb(NCT5523D_INDEX_PORT, REG);
    Result = inportb(NCT5523D_DATA_PORT);
    Lock_NCT5523D();
    return Result;
}
//-----
```